

CHAIN HOIST

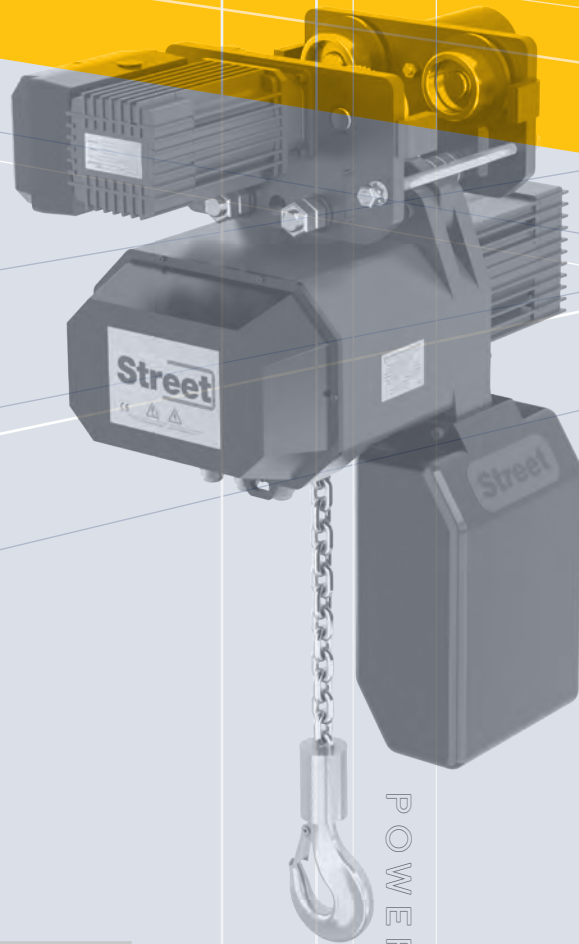

POWER AND DURABILITY

Street

PERFORMANCE THROUGH EVOLUTION AND INNOVATION

Street



“To achieve the highest possible levels of performance and reliability it is necessary to continuously learn from experience...

...Invest in R&D and pay attention to even the smallest possibility for improvement. Only then can new bench marks for efficient performance and operating reliability be set. Only then can a technology be said to be truly proven.”





LX CHAIN HOIST: power and durability.

Most of our lifting and transportation solutions for light loads are powered by the Street LX electric chain hoist which provides precision lifting and durability at surprisingly attractive prices.

The LX hoist is designed to meet the need for ultra efficient lifting and material handling in today's competitive world.

This new generation hoisting technology is based on a highly modular and versatile concept with a huge number of hoist and trolley constructions.

"A hoist for tomorrow's world in which, only the most productive will prosper."

The LX range is available in capacities from 125kg up to 5 tonne in almost every world supply voltage with single and dual speed options. Hoists are available in standard headroom construction or low headroom with chain diverter. LX hoists are designed for applications with eye suspension or powered, push, or hand geared trolley. All capacities are available at M5 (FEM 2m) with a wide variety of hoist speeds. All standard models are manufactured with rated capacities in metric tonnes or U.S. tons.



Hoist motor

- Powerful 3 phase motor
- Improved ventilation to protect against overheating
- Single or dual speed
- Class "F" insulation
- I.P 54 or I.P 55 protection (depending on model).
- 50 or 60 Hz solutions
- Available in almost every world supply voltage

Hoist brake

- Heavy duty long life hoist disc brake
- Low maintenance
- High efficiency
- Asbestos free linings
- Easy adjustment

CNC Machined Hoist Gearbox

- High performance low noise
- Hardened and heat treated gears
- Compact design
- Operates efficiently from -20 to +50°C (-4 to 122°F)



LX HOOK SUSPENSION

Solo or integrated, pendant or remote control

- Standard 48 Volt push-button pendant for solo hoists
- Solo radio remote control
- Integrated pendant or remote radio for bridge crane and jib solutions

Optional equipment and specifications

- Quick release electrics with plug and sockets for crane applications
- Trolley limit switch
- I.P 55 and I.P 65 electrical enclosures
- Upper and lower limit switches (standard on all LX3 models)
- Single phase 230v and 110v solutions.
- Inverter on trolley motion



Overload protection / hoist and lower limit switches

- Friction type torque limiting slipping clutch
- Prevents over hoisting and over lowering
- Easy adjustment
- Prevents operator overloading the hoist
- Effective protection of the hoist motor

Durable chain, drive sprocket and guide

- High accuracy CNC machined drive sprocket
- Geometrically precise chain
- High tensile zinc coated
- High resistance to wear and corrosion
- Precision calibrated chain guide

Chain collection

- Compact durable chain collection container
- Various sizes depending on chain length

LX

HOIST

LX CHAIN HOIST:

impressive range of standard safety and operating features plus optional equipment.



LX series



LX STANDARD HEADROOM HOIST WITH POWERED TROLLEY



LX STANDARD HEADROOM HOIST WITH PUSH TROLLEY

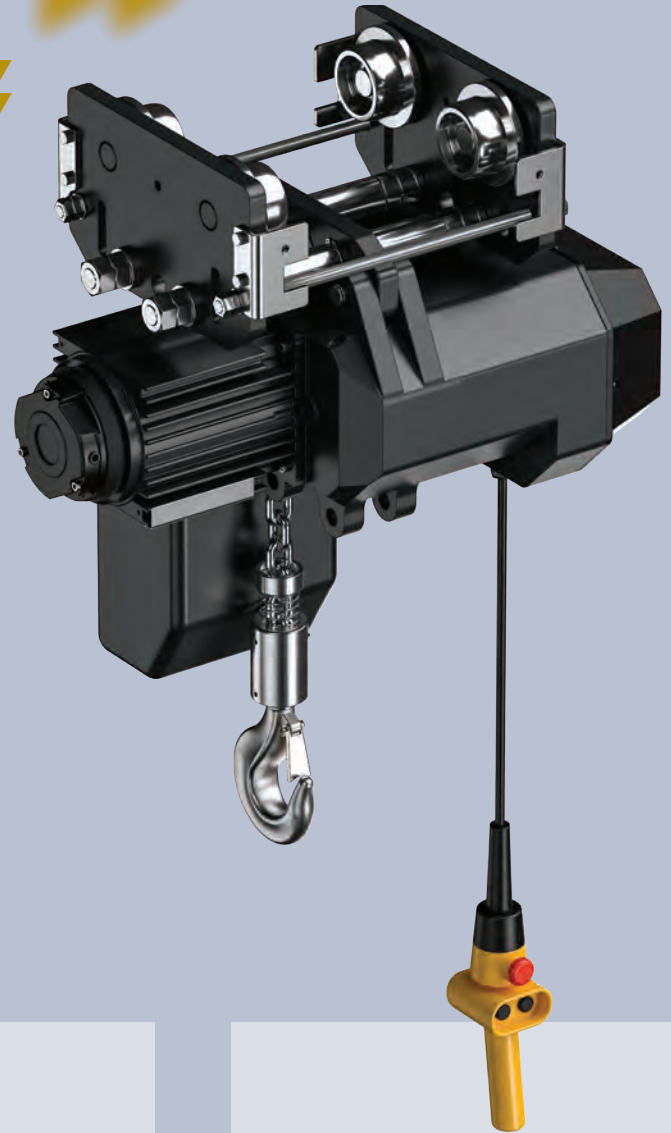

Standard or low headroom construction

The Street LX chain hoist is one of the most comprehensive ranges of electric chain hoist in the market with global distribution. All models and capacities are available in standard headroom construction with a range of adjustable powered or push trolleys. These are designed for monorail or single beam applications such as bridge cranes or jib cranes but twin beam solutions are also possible. Additionally eye suspension models for stationary hoist applications or applications with suspension trolley such as light crane and profile track systems are included in the range.

Standard headroom and eye suspension models optimise side hook approaches but for those applications where upper hook position is critical in a restricted roof height the Street low headroom hoist with chain diverter trolley provides an unbeatable compact solution.

chain hoists

capacities up to 5 tonnes



LX EYE SUSPENSION HOIST

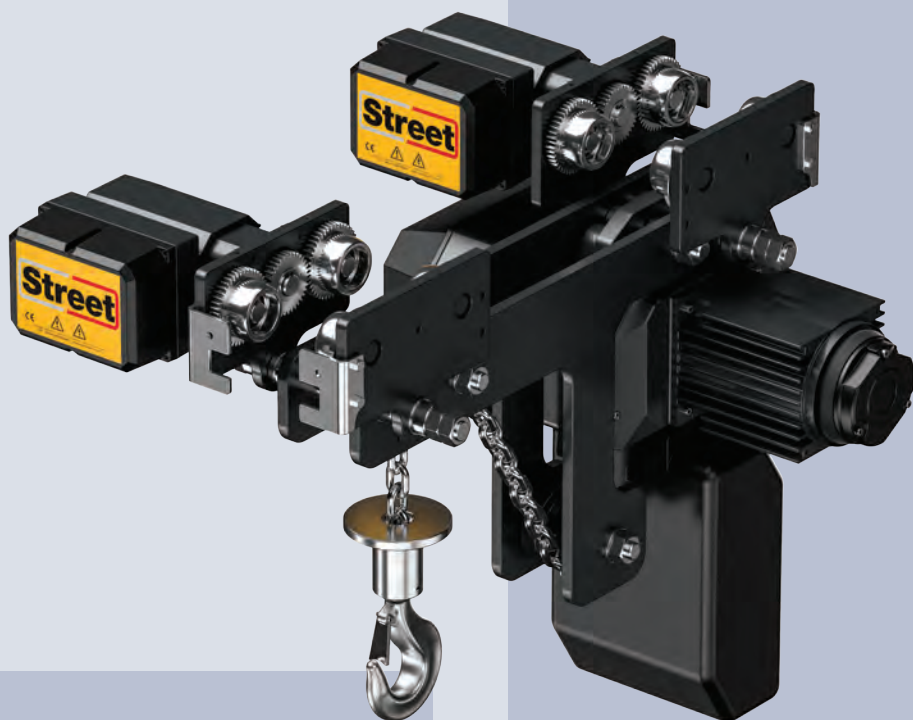

LX LOW HEADROOM HOIST WITH POWER TROLLEY



Finish

- Durable polyurethane powder coating

Lifting hook

- DIN standard hook with safety catch
- Spring loaded safety catch fitted as standard

LX Chain Hoist Applications: Street 'LCS profile' crane



Street 'bridge crane'



Street LX chain hoists are designed and built to give reliability and endurance in a wide range of industrial applications such as manufacturing, service and maintenance but our customers and distributors continually surprise us with new and innovative ways to use our products. We therefore have installations in sports, entertainment, scientific and military applications. For bespoke applications with curved monorail beams, the standard LX is suitable for a min. 900mm radius.



LX Chain Hoist Applications: Street slewing jib crane

LX HOISTS:
Robust construction
Long service life

Street LX chain hoists are designed and built to give reliability and endurance in a wide range of industrial applications such as manufacturing, service and maintenance but our customers and distributors continually surprise us with new and innovative ways to use our products. We therefore have installations in sports, entertainment, scientific and military applications.

The LX chain hoist is the smallest member of a successful family of Street hoists. The Street ZX and VX electric wire rope hoists are available in capacities up to 200t. LX is the product of meticulous research and development using advanced design methods including the latest solid modelling and finite element analysis.

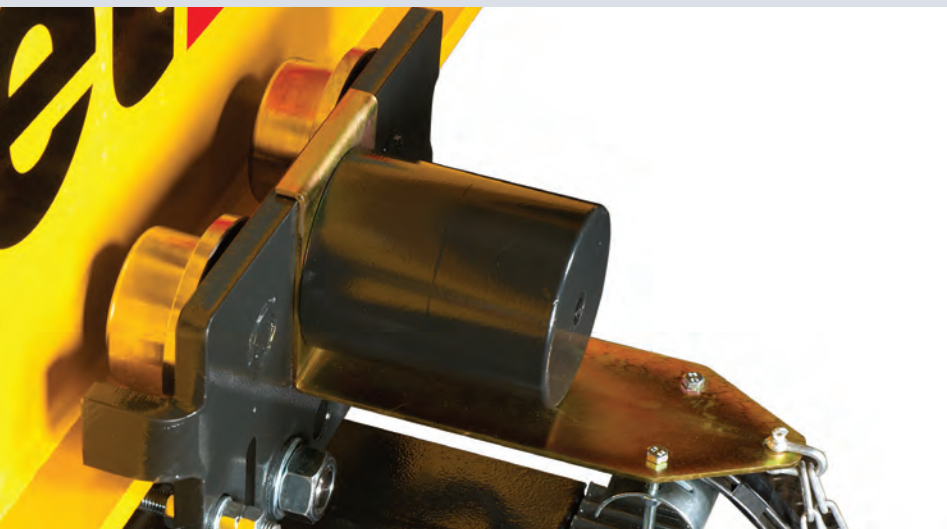
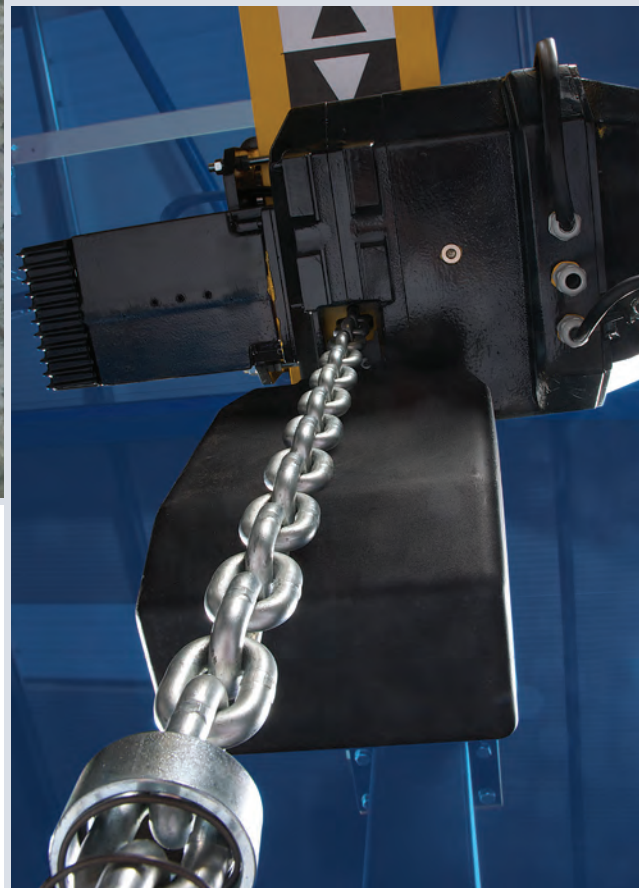

www.streetcrane.co.uk

Street

Street Crane Company Limited, Chapel-en-le-Frith, High Peak, SK23 0PH, United Kingdom.
Email: admin@streetcrane.co.uk Web: www.streetcrane.co.uk
Telephone: +44 (0) 1298 812456 Fax: +44 (0) 1298 814945



Certificate No. FM13635

